



Company Overview & Divisions

Executive Summary



IDM Products, LLC is a minority-owned national supply chain and manufacturing company based in Dallas, Texas. We specialize in procurement, manufacturing, asset tracking, distribution, logistics, warehousing, sustainable packaging and strategic sourcing. Our state-of-the-art manufacturing facility is home to our exclusive line of EPA-registered Easy Pro Wipes, which includes industrial, disinfectant, isopropyl, pet, and dry wipes. We are also distributors of JanSan, MRO, maintenance products, office supplies, healthcare products, foodservice disposables and various types of furniture.

Serving as the extended purchasing arm for numerous organizations, we oversee the material flow in designated locations, which drives significant process efficiencies and cost savings for our clients. What truly distinguishes us, however, is our capacity to craft unique, innovative value-added solutions that not only fulfill but surpass the requirements of an ever-changing market. Our laser-focused approach is sharply attuned to our clients' needs, enabling us to create tailored solutions to tackle their most pressing challenges.

IDM at a Glance



CORE COMPETENCIES:

- eMarketplace Procurement Solutions
 - Building Maintenance Products
 - JanSan
 - Foodservice Disposables
 - MRO
 - Office Supplies
 - Furniture
- Wipes Manufacturing
- Asset Tracking Technologies
- Global Sourcing Capabilities
- Full-Service Supply Chain & Logistics
- Distribution
- Short / Long-Term Warehousing
- Pallet Sourcing
- Sustainable Packaging
- Textiles

STRATEGIC CUSTOMER PARTNERS:



• Federal Reserve Bank of San Francisco



amazon | project kuiper

What Guides Us



At IDM Products, our mission is to empower businesses with streamlined and innovative products and solutions. Through the synergistic power of our nine divisions, we act as catalysts for business transformation, providing efficient, tailored and responsible procurement, manufacturing, distribution, sustainable packaging, logistics, and warehousing services, as well as cutting-edge technology solutions that enable our clients to thrive and succeed in their respective markets.

Our commitment to exceptional service guides us in forging lasting partnerships. By continuously adapting to the evolving market needs, understanding our clients' unique needs, and engaging with them in a highly collaborative way, we aim to set industry standards and elevate the businesses we serve, reaffirming our position as a trusted partner for supply chain excellence.



MISSION

IDM Products' Competitive Advantage



SOURCING & PROCUREMENT

- Vast expertise in sourcing hard-to-find items
- Global sourcing capabilities
- Flexible solutions to our customers' unique supply chain challenges and white glove service
- Strategic partnership with Coupa e-Procurement



PRODUCTS & SERVICES

- Broad product reach, including domestic and international brands
- More than 1.5 million SKUs across many categories
- Instant access to pre-negotiated prices through Coupa Advantage Express Catalogs



MANUFACTURING & LOGISTICS

- With 30+ distribution centers nationwide, delivery in 1-3 business days to more than 90 percent of the U.S
- Full-service supply chain and logistics company with global capabilities
- Manufacturer of disinfectant & industrial wipes



PEOPLE

- Highly experienced team with expertise in manufacturing, supply chain, logistics and more
- Carefully nurtured relationships across multiple industries
- Our team can handle and meet customers' needs.

IDM Products' Divisions



We invested in state-of-the-art equipment to manufacture our Easy Pro line of wipes.

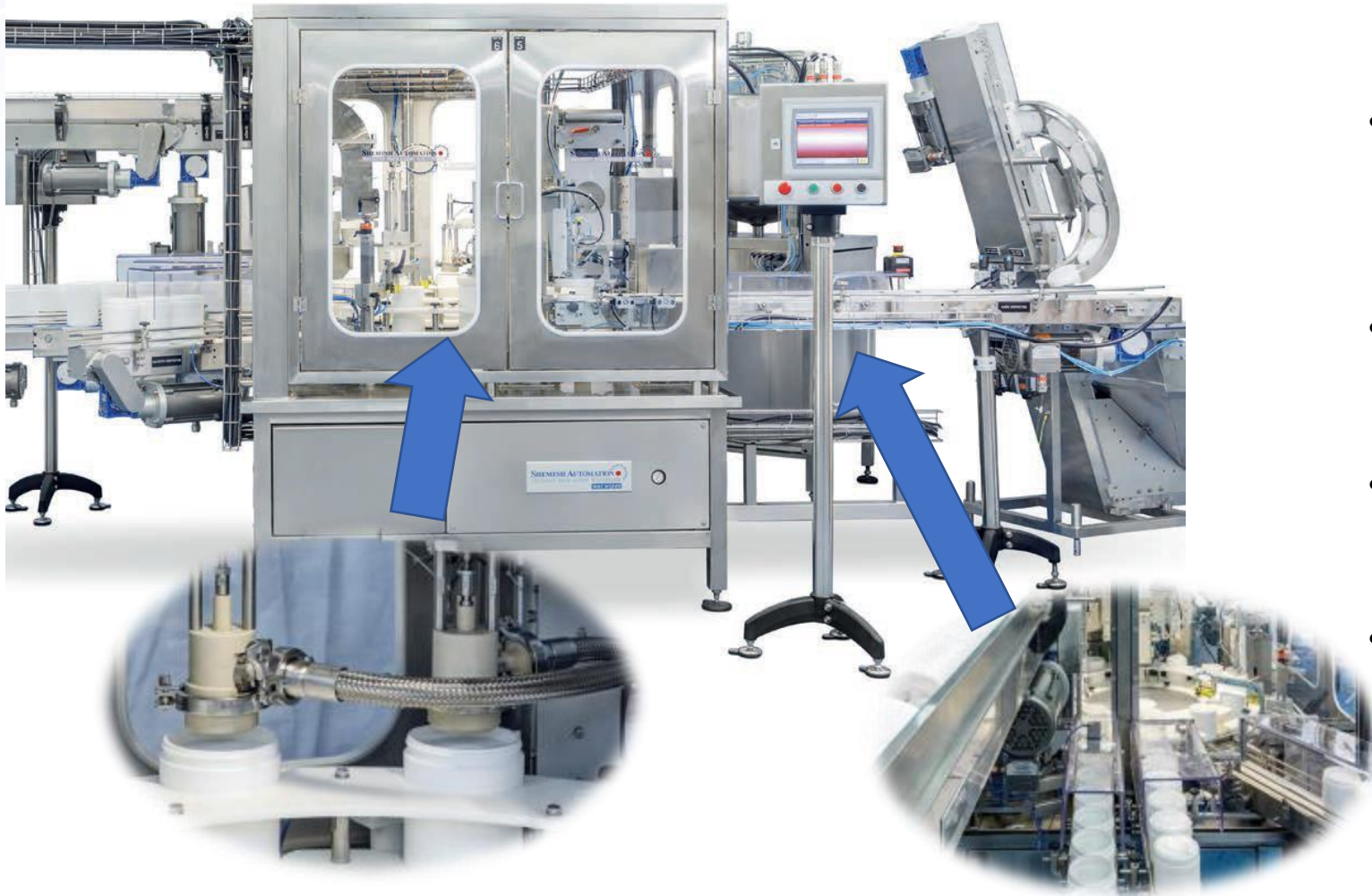

XPANDER

- Specifically designed for round, non-woven wipes in round and/or oval, and/or conical canisters.
- Features automatic canisters and lids-feeding, filling, closing, sealing.
- Allows for capping, smart quality control, discharging and can wipes loading.
- Produces 30-35 products per minute throughput.

Asset Visibility

Asset Visibility POWERED BY LINK LABS

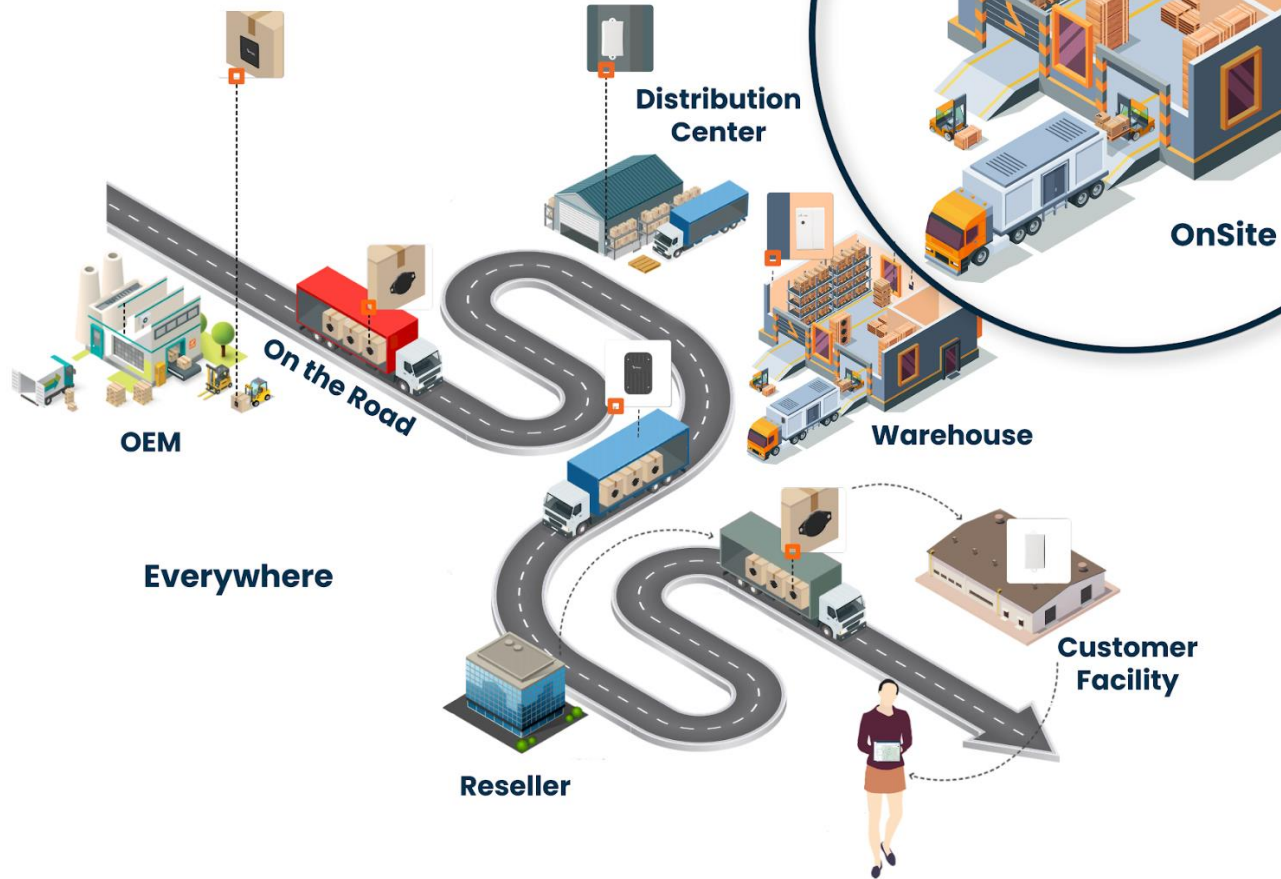

Click for a
Quick Overview

Where Assets Are

Up to 30cm location accuracy | Indoors & outdoors
At any time | In most countries | Via a single pane of glass

How Assets Are Doing

Temperature | Humidity | Shock | Tampered
Open/closed | +any BLE sensor

What Assets Are Doing

Crossing outdoor or indoor boundaries | Dwell times
Transit times | Separated from a group | Route history

Distributor of 1.5+ Million Branded & Private Label Products



FLUKE



PHILIPS



Our Distribution and Sales division is responsible for the following activities:

- Managing the sales lifecycle from quotes to purchase orders and final fulfillment of the order.
 - Forging strategic partnerships with our customers, collaborating closely to assist them in effectively managing their business expenditures, while fostering mutual business growth.
 - Providing white glove customer service.
 - Seeking and establishing relationships with hundreds of new manufacturers and distributors.
-

Medium and large enterprises benefit from IDM Products' eMarketplace technology, which automates and simplifies electronic procurement processes.

- **eCommerce Integration.** Fully supported cXML punchout catalog for lifetime integration, with experienced technical resources.
 - **Complimentary Access to Instant Catalogs.** We offer onboarding, integration, testing, servicing, technical assistance and troubleshooting at no cost to our customers.
 - **Competitive Pricing.** Catalogs come pre-configured out-of-the-box with pre-negotiated pricing. If our customers are interested in customized punchouts, we will work directly with them to expedite the onboarding process.
 - **Trusted Suppliers.** We follow a thorough supplier vetting process to ensure we can reliably deliver products to our customers.
-

Strategic Sourcing / Special Projects



IDM Products gained the reputation of successfully sourcing and developing solutions for unique needs and projects. Our capabilities have allowed us to develop and implement efficient solutions in the areas of **warehousing, manufacturing, commodities, sustainable packaging** and more.

IDM is a global importer of raw materials, further highlighting our diverse portfolio of quality materials and utilizing our specialized team of technical and business professionals to innovatively link our global resources with our partners' local requirements.

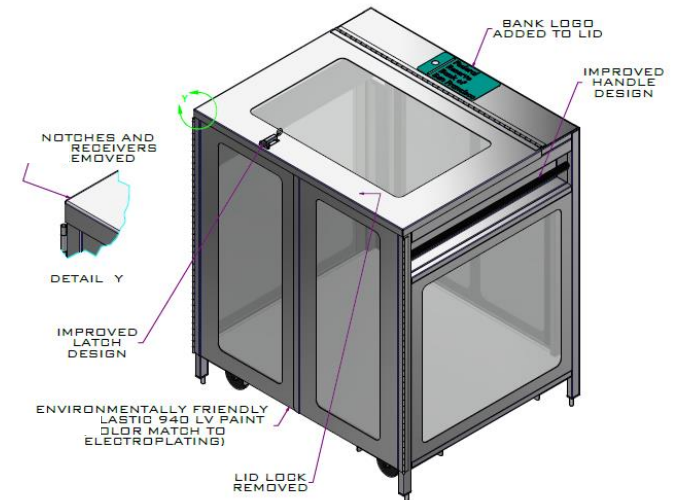
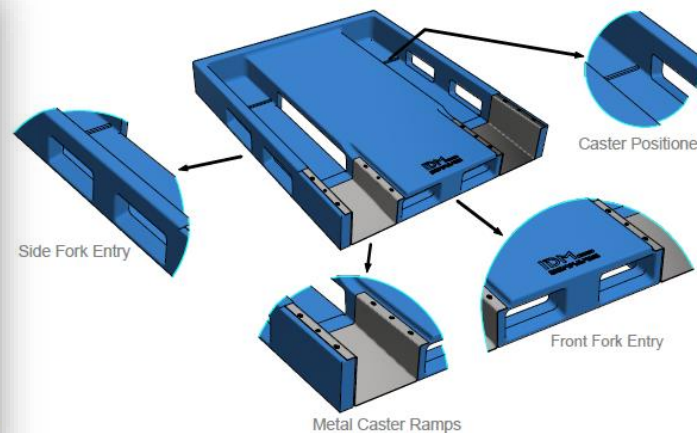

LFP Logistics Group, LLC is a Dallas, Texas-based, full-service, minority-owned, multi-modal logistics company. Fully embedded with IDM Products, our goal is to centralize logistics, manufacturing and supply chain into one hub of services for our customers.

Convenience for Shippers

- Real-time visibility and control of supply chain performance
- Delivers to 90 percent of the U.S in 1-3 business days
- Quote, book and track Truckload, Less Than Truckload & expedite shipments with one tool
- Intuitive, automated and streamlined to speed up quotes and reduce error
- Easily generate reports providing a variety of pertinent data

Managed Transportation

- Logistics consulting and analysis
- Freight bill payment and audit
- Reporting and performance management
- Shipment planning and execution
- Dedicated account teams
- Carrier management
- Transportation management system

Supply Chain Management

- White glove, in-store/in-home delivery
- Assembly and debris removal
- Limited access/final mile delivery
- Warehousing/cross-docking
- Chargeback avoidance strategies

Warehouse Solutions



- Secured, specialized warehouses, in addition to logistics services
- Flexible short- and long-term lease agreements
- Warehouse management and storage services
- Additional storage space
- Array of pallet types available

Sustainable Packaging

Our Services Framework



DESIGN FOR SUSTAINABILITY

Partner with design experts to develop packaging formats to drive faster eco-friendly validation.



MATERIALS SOURCING & DEVELOPMENT

Determine the best sustainable materials for your package and source them intelligently, while factoring for price, supply, and technical performance.

IDM Packaging Solutions' expanding capabilities also incorporate manufacturing and distributing intelligent, active, rigid and sustainable packaging. We have resources and experience to deliver innovative, sustainable packaging for consumer products from food and beverage, to home and personal care. Through our carefully constructed relationships with several of the world's leading sustainable corporations, we are able to help create differentiated products addressing the requirements of a rapidly changing consumer landscape, driving both performance and customer value.

Purposeful innovation, advanced conversion capabilities and best-in-class manufacturing practices are several of the drivers enabling us to co-develop game changing rigid packaging for our customers.



Our Framework Benefits

- Design process reduces risks associated with new sustainable packaging formats.
- Our materials sourcing and development provides access to approved sources of recyclable, bio-degradable / compostable resins.

Textile Solutions



A SUBSIDIARY OF
IDM PRODUCTS
INNOVATION IN MOTION

www.SavvyChicPawz.com



COZY PLAID COLLAR



RED AND BLACK PLAID COLLAR



TWINKLING TREES BLUE COLLAR



TWINKLING TREES RED COLLAR



GINGERBREAD MAN SLIP-ON BANDANA



HANUKKAH SLIP-ON BANDANA



HOLIDAY PENGUINS SLIP-ON BANDANA



HOLIDAY PLAID SLIP-ON BANDANA

Our textile division can customize needs from industrial apparel (medical grade, reusable gowns), to quality, handmade pet accessories and more. Our textile division at IDM Products offers a wide range of customizable solutions to meet various needs.

From industrial apparel such as medical-grade reusable gowns to high-quality, handmade pet accessories, we cater to diverse requirements. Whether it's providing protective clothing for specialized industries or creating unique and stylish accessories for pets, our textile offerings are designed to meet the highest standards of quality and customization. With our expertise in textiles and commitment to customer satisfaction, we deliver products that combine functionality, durability, and aesthetic appeal.



INNOVATION IN MOTION

THANK YOU



10460 Markison Rd. Dallas, TX 75238



sales@idmproducts.com



www.idmproducts.com